

Installation Instructions For Aleddra's emergency LED T5 lamps

WARNING - RISK OF FIRE OR ELECTRIC SHOCK. LUMINAIRE'S WIRING, BALLASTS, OR OTHER ELECTRICAL PARTS MAY BE DAMAGED WHEN DRILLING OR INSTALLATION OF REFLECTOR. CHECK FOR ENCLOSED WIRING AND COMPONENTS.

WARNING - RISK OF FIRE OR ELECTRIC SHOCK. RETROFIT KIT INSTALLATION REQUIRES KNOWLEDGE OF FLUORESCENT LIGHTING LUMINAIRE ELECTRICAL SYSTEMS. IF NOT QUALIFIED, DO NOT ATTEMPT INSTALLATION. CONTACT A QUALIFIED ELECTRICIAN.

WARNING - RISK OF FIRE OR ELECTRIC SHOCK. INSTALL THIS KIT ONLY IN THE LUMINAIRE'S THAT HAVE THE CONSTRUCTION FEATURES AND DIMENSIONS SHOWN IN THE DRAWINGS.

WARNING - TO PREVENT WIRING DAMAGE OR ABRASION, DO NOT EXPOSE WIRING TO EDGES OF SHEET METAL OR OTHER SHARP OBJECTS.

WARNING - LAMP CONTAINS A BUILT-IN LI-ION BATTERY AND MUST BE RECYCLED OR DISPOSED OF PROPERLY IN ACCORDANCE WITH LOCAL REQUIREMENTS.

IMPORTANT

DO NOT MAKE OR ALTER ANY OPEN HOLES IN AN ENCLOSURE OF WIRING OR ELECTRICAL COMPONENTS DURING KIT INSTALLATION.

INSTALLATION OF THIS RETROFIT ASSEMBLY REQUIRES A PERSON FAMILIAR WITH THE CONSTRUCTION AND OPERATION OF FLUORESCENT LUMINAIRE ELECTRICAL SYSTEMS AND THE HAZARD INVOLVED.

DO NOT USE THIS EQUIPMENT FOR OTHER THAN ITS INTENDED USE. THE USE OF ACCESSORY EQUIPMENT NOT RECOMMENDED BY ALEDDRA MAY CAUSE AN UNSAFE CONDITION.

ONLY USE THE PROVIDED LAMP HOLDERS AND REWIRE TO LINE VOLTAGE. AFTER REWIRING, THE LUMINAIRE WILL NO LONGER OPERATE A FLUORESCENT LAMP.

THE LAMP IS INTENDED FOR USE IN DRY LOCATIONS ONLY. DO NOT USE OUTDOORS.

THIS PRODUCT MUST OPERATE AT A DEDICATED VOLTAGE OF 110 ~ 277VAC. ALWAYS TEST CIRCUITS BEFORE INSTALLATION WITH A VOLTAGE TESTER. STANDARD MAINS AND EMERGENCY MAINS MAY BE PROVIDED BY SEPARATE CIRCUITS.

NOTICE TO THE INSTALLER: PLEASE ADHERE THE ATTACHED LABEL WHERE VISIBLE DURING RELAMPING EITHER ON THE BALLAST TRAY OR ON REFLECTOR.

BEFORE REPLACING THE EXISTING FLUORESCENT TUBE, ALWAYS DISCONNECT THE POWER TO THE FIXTURE. THIS PRODUCT IS INTENDED TO USE WITH UL APPROVED LINEAR FIXTURES ONLY.

LIST OF COMPONENTS:

- EMERGENCY LED T5 LAMP X 1 (ONE ENDCAP WITH A RED STRIPE)
- NON-SHUNTED LAMP HOLDER X 2 (ONE WITH A WHITE ROTOR AND THE OTHER ONE WITH A BLACK ROTOR)
- INSTALLATION INSTRUCTIONS X 1
- THE LUMINAIRE WARNING LABEL X 1

INSTALLATION INSTRUCTIONS

1. Disconnect power to the fixture
2. Remove existing fluorescent tubes.
3. Remove ballast cover
4. Cut all the wires to ballast and remove the ballast
5. Remove existing lamp holders
6. Install the non shunted lamp holders provided with the aleddra's emergency LED T5 lamp retrofit kit into the fixture: Refer to wiring diagram in Fig. 1

- Connect lamp holder 1 with the black-rotor to EMERGENCY MAINS through circuit breaker 1, which will be “off”only during power outages.
 - Connect lamp holder 2 with the white rotor to standard MAINS through circuit breaker 2, which is typically connected to a wall switch.
7. Reinstall the ballast cover.
 8. **IMPORTANT:** Turn on a battery connection switch near the endcap with the red stripe. The battery connection switch comes with a default “off ”to prevent the built-in battery from being depleted and damaged. The lamp may be lighted in a dimmed light level powered by the built-in battery (see Fig. 2).
 9. Install the lamp in the lamp holders, matching the endcap with the red stripe to the lamp holder with the black rotor (i.e. connect BLACK to RED). The lamp will have to be rotated to receive power
10. Adhere the attached notice label to the reflector of the luminaire.
 11. Turn on both the breaker 1 and the breaker 2 and allow for emergency and standard power to the fixture. The lamp should be lighted at full power. The green LED should be on to indicate normal AC MAINS exist.
 12. Regulatory compliance tests: Allow the lamp on the fixture for 24 hours with EMERGENCY MAINS on. Turn off both the breaker 1 and the breaker 2 and observe the EM LED T5 lamps under test to determine if they work for a 90-minute (annually) or a 30-second (monthly) testing period. The green LED will be off. If any of the lamps are not lighted during the test period, contact [Aledra](#) to replace the lamps. Written records documenting the testing must be maintained and available for review by local fire departments.

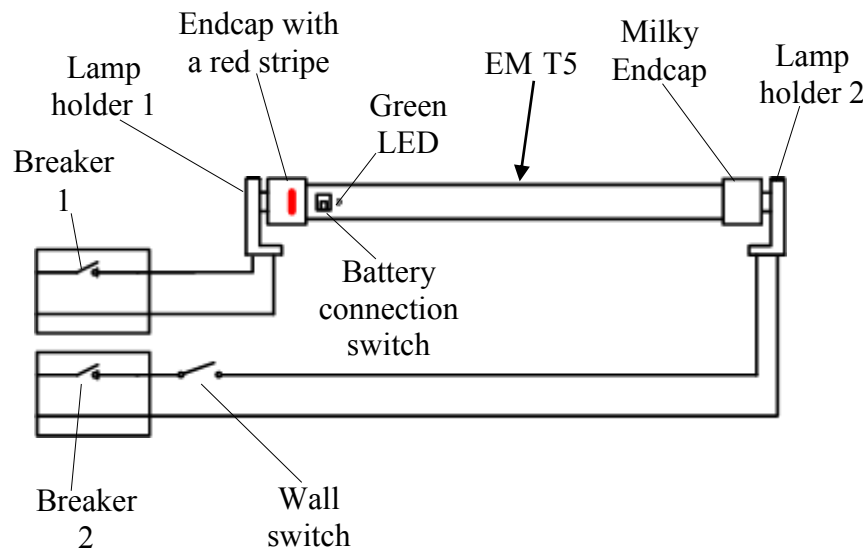

Fig. 1

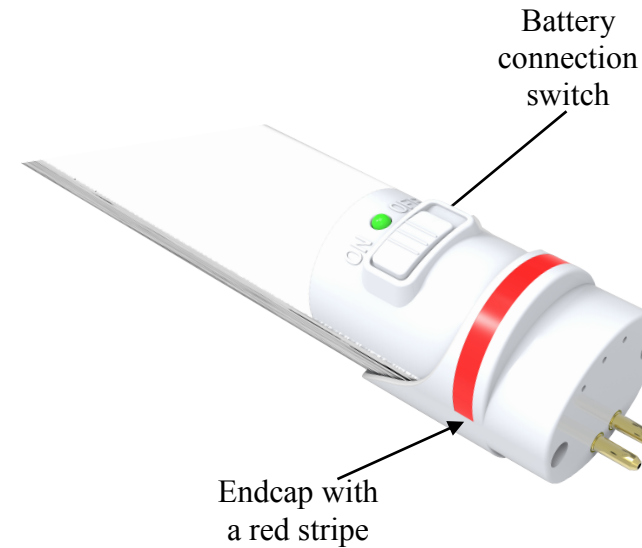

Fig. 2